

GHG-JHM20 Soft Close Damper Hinge

Features

- Built-in damper provides soft close motion and keeps lid from slamming shut
- Smooth movement in the opening direction
- Mortise mount type
- Easy to cut out with a router
- Cover hides mounting screws for clean appearance
- Passed 20,000 life cycle test

Notes

- Sold in pairs
- Ensure both hinge shafts are levelled and aligned during installation
- Damper mechanism works when opening the lid by about 60° or more



Top View

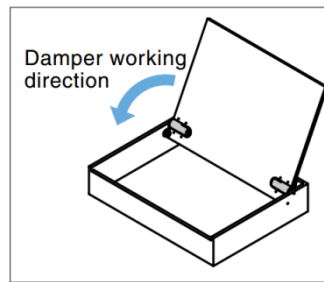
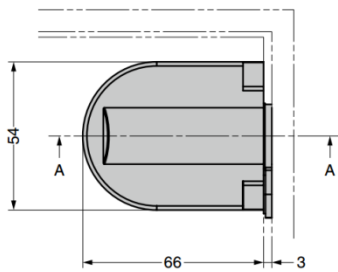

Installation

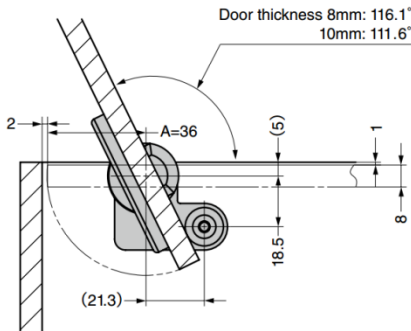

※ If the distance from the screw hole to the edge is 5mm, a level difference of 1mm is generated.

※ Min. door thickness 8mm

Cut Out Dimensions

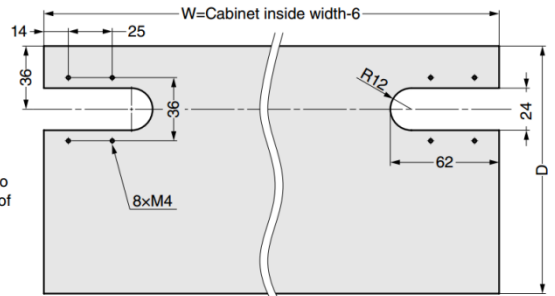

Cross-section Drawing

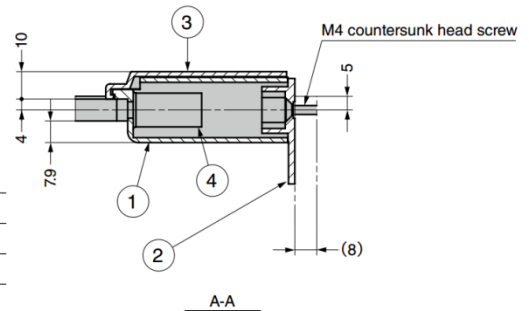

No.	Part Name	Material	Finish / Colour
①	Body	POM	Black
②	Bracket	Aluminium Alloy (ADC)	Black Enamel Finish
③	Cover	ABS	Black/White
④	Damper	-	-

Part No.	Colour	Marking Colour (Base Side)	Torque (per pair)
GHG-JHM20-80BL	Black	Yellow	6 ~ 8 N.m 61.2 ~ 81.6 kgf.cm
GHG-JHM20-80WT	White		